

Official Notice Board

J/70

TÜRKİYE CLASS ASSOCIATION

2023 TOUR of TÜRKİYE

2nd LEG Marmaris

Supplement

07 – 09 APRIL 2023

1. GENERAL INFORMATION

- 1.1. Official Online Notice board will be set at <https://www.racingrulesofsailing.org/documents/5625/event>
- 1.2. The organizing authority is J/70 Turkish Class Association (J/70 TCA)
- 1.3. Race Office will be T.B.A.

2. RULES

- 2.1. World Sailing Racing Rules of Sailing, RRS 2021-2024
- 2.2. J/70 Class Rules 2023
- 2.3. The J/70 TCA 2023 Standard Sailing Instructions, the applicable Supplement and amendments.
- 2.4. If there is a conflict between the rules above, the Standard Sailing Instructions, Supplement and their amendments will be valid according to their date. This changes RRS 63.7.
- 2.5. The sunset time for this Race will be 1909hrs. (local)
- 2.6. Only for T.C. Citizens: TYF Sporcu Lisans, Tescil, Vize ve Transfer Talimatı, Disiplin Suçları ve Cezaları Talimatı. These prescriptions shall not apply to foreign competitors.
- 2.7. Times shown are local (GMT+ 2 /Istanbul)
- 2.8. Official language shall be in English.
- 2.9. If there is a conflict between texts, English text shall take precedence.
- 2.10. RRS Appendix P (Special Procedures for Rule 42)

3. REGISTRATION

- 3.1. The documents listed in Article 6 of the Tour of Turkey NoR regarding registration must be send to ***J70.kayit@gmail.com*** on 05 April 2023 at the latest, and the original copies must be delivered to the Race Secretariat at 1000 (local). (ref:NoR/art6.3)
- 3.2. Entry fee is 7.000TL for other fees see (ref:NoR/art7)
- 3.2.(a) Bank account for the fees and annual membership dues: TR60 0006 2001 6050 0006 6991 66, Nazmi Ahmet Eker J 70 TSB 2023 1st Leg (Registration fee & dues etc.) must be transferred to this account with explanation before registration.
- 3.2.(b) Protest guarantee is 500 TL. This deposit is refunded if the protest is won or withdrawn. Otherwise, protest guarantee will be recorded as revenue by TCA.(ref:NoRart.7.4)
- 3.2.(c) The above-mentioned registration fee and dues must be paid before the race.
- 3.2.(d) Only TSF licensed sailors can participate in this race, "Temporary License" will not be applied. These prescriptions shall not apply to foreign competitors.
- 3.3. Each boat owner/responsible will provide a crew list along with the registration form App.#B. Detection of a competitor on the boat who is not on the crew list or who is not on the boat although his name is on the list may be grounds for disqualification (DSQ) by the Protest Committee.
- 3.4. Every change of a crewmember shall be declared to the RC no later than two (2) hours before the scheduled time of the first warning signal of the day. Crew substitution should be done from Official Online Notice Board.
- 3.5. The venue is Marmaris Bay (ref:NoR/art.13)
- 3.6. Coach/support boats should register to the Race Office before the first race.
- 3.7. For Press/media members should register no later than 05 April 2023

4. FORMAT AND PROGRAM OF THE RACES (ref: NoR/art.10)

- 4.1. All competing boats have bow number as required by TCA
- 4.2. Skipper meeting will be held on 07 April 1000(local) at Race Office.
- 4.3. Eight (8) race are scheduled.
- 4.4. On each race day, the warning signal time for the first race of the day will be 1200 hrs (local)
- 4.5. The starts will be made in accordance with RRS26 (5 minutes-4 minutes-1 minutes –START).
- 4.6. No warning signs will be given after 1400 on the last day of the races.

5. BERTHING (ref: NoR/art.18)

- 5.1. To be announced later.
- 5.2. Lift service will be TBA

6. SOCIAL ACTIVITIES

- 6.1. T.B.A

J/70 TÜRKİYE CLASS ASSOCIATION
25th March 2023; Time:1200 (local) / revised 1900(local)

APPENDIX A: BOW NUMBER POSITIONING

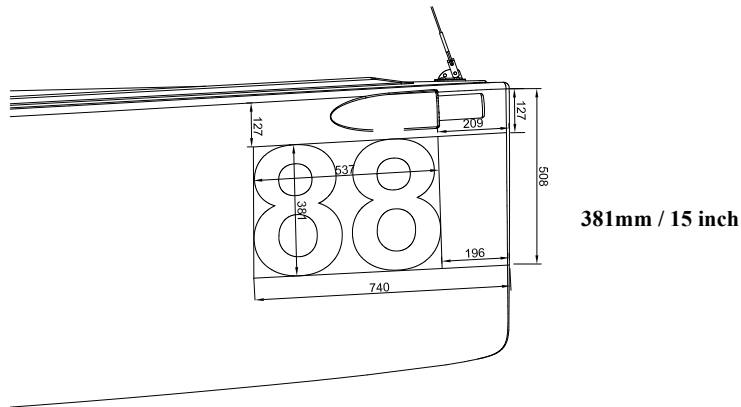

J/70 Class Bow Number Location & Size #1

Standard number - height = 381mm (15")
Dimensions in mm
6-11-2018

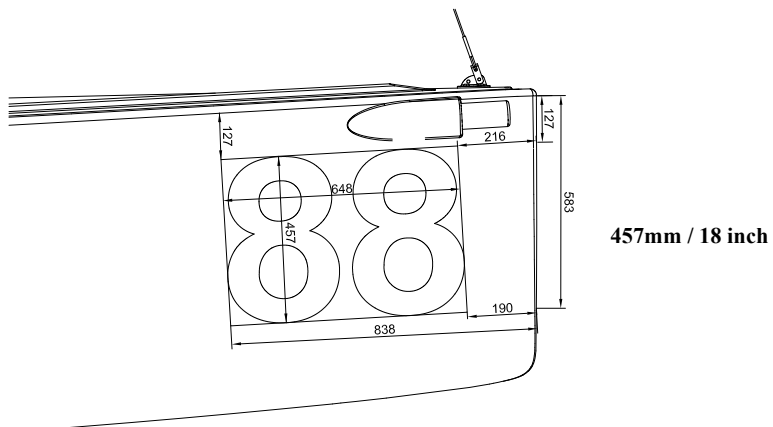

J/70 Class Bow Number Location & Size #2

Large number - height = 457mm (18")
Dimensions in mm
6-11-2018

ATTACHMENT B

COURSES

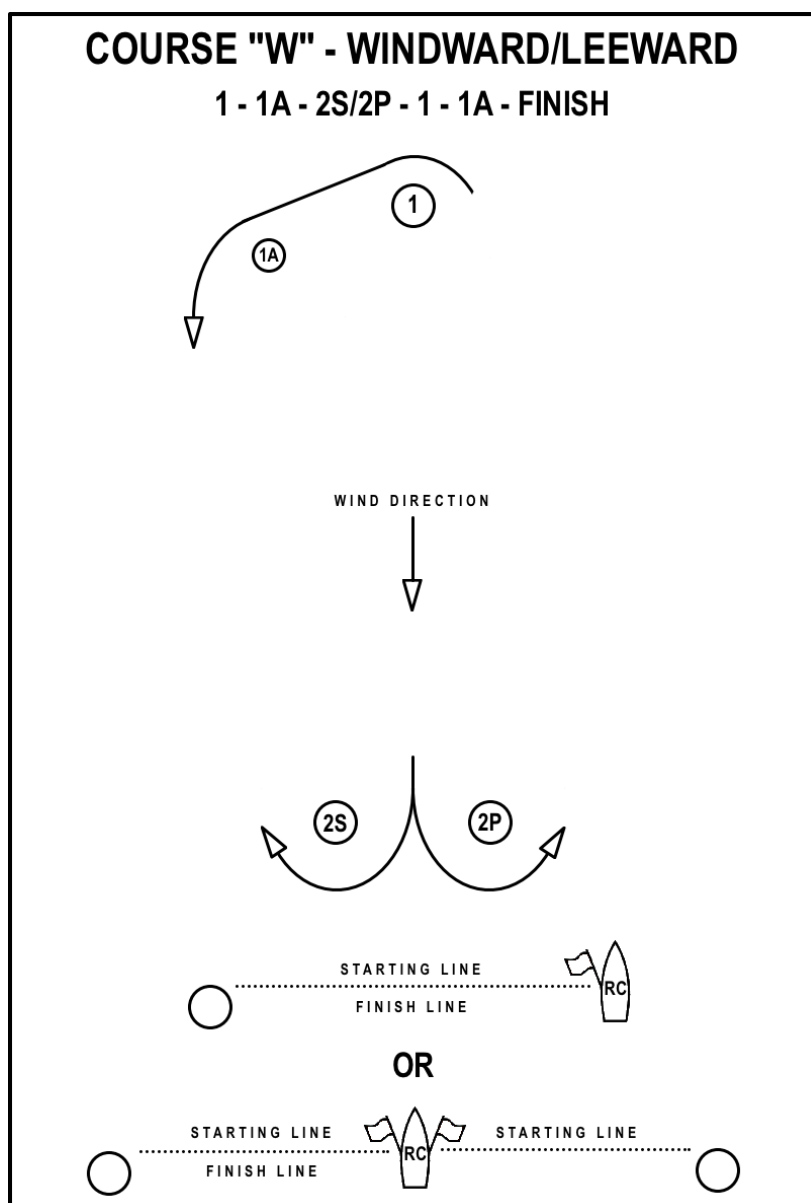

Course W is to be used for racing with one fleet. Fleets of 60 or more boats may use a mid-boat line as shown in the diagram. Starting marks may be marks or boats.

For Continental and World Championships, the RC shall use two finish boats, one at each end of the line. For other events, the use of two finish boats is optional.

ATTACHMENT C

YARIŞ KAYIT FORMU /REGISTRATION FORM

2023

Tour of TÜRKİYE TURU 2.AYAK

CORINTHIAN DIVISION YES () /NO ()

Boat	Name Surname	TC ID no	TYF Licence No./ Club / City	ISAF ID /GR.
1	Owner/Driver			
2				
3				
4				
5				
6				

Bu yarışta WS, TYF, J70 sınıfı kuralları ve J70 TSB 2023 Standart Yarış Kuralları hükümlerine uygulamakla yükümlü bulunduğumu, yarış esnasında meydana gelebilecek her türlü can ve mal kayıp ve zararı için Organizasyon, Yarış, Teknik ve Protesto Komiteleri'nin mesul olmayacağımı beyan ve kabul ederim

I declare that, I agree to be bound by WS, TSF (Turkish Sailing Federation) racing rules, J70 class rules and J/70 TCA 2023 SSI. I understand that the OA, RC, TC and PC accept no responsibility for loss of life or injury to members and others, or for the loss of, or damage to any vessel.

Tekne Sahibi / <i>Owner of the boat</i>	
Adresi / <i>Address</i>	
Cep Tel / <i>Mobile Phone</i>	
E-posta / <i>E-mail</i>	
Tarih / <i>Date</i>	
İmza / <i>Signature</i>	

ATTACHMENT D

RRS APPENDIX P, Special Procedures for Rule 42 is replaced in its entirety with:

P1 OBSERVERS AND PROCEDURE

A member of the International Jury, protest committee, or its designated observer (collectively, the “observer”) who sees a boat breaking

- ✚ RRS 42 (Propulsion),
- ✚ RRS 49 (Crew Position; Lifelines),
- ✚ J/70 Class Rule (J70CR) C3.3 (Crew Positioning) or
- ✚ J70CR C9.4(b)(1) (Bowsprit Use)

may penalize her by, as soon as reasonably possible, making a sound signal, pointing a yellow or red flag at her and hailing her bow or sail number, even if she is no longer racing. A boat so penalized shall not be penalized a second time under rule 42 for the same incident.

P2 PENALTIES

When a boat is penalized under rule P1, her penalty shall be a One-Turn Penalty under RRS 44.2. If she fails to take it, she shall be disqualified without a hearing. If an observer signals a penalty after a boat has finished, her penalty shall be a ten percent (10%) scoring penalty calculated per RRS 44.3(c).

P3 POSTPONEMENT OR GENERAL RECALL

If a boat has been penalized under rule P1 and the race committee signals a postponement or general recall, the penalty is cancelled.

P4 REDRESS LIMITATION

A boat shall not be given redress for an action by an observer under rule P1 unless the action was improper due to a failure to take into account a race committee signal or a class rule.